



# INSTALLATION MANUAL

FIBER OPTIC SPLITTER CLOSURE

AR-SC9P-144F-M

AR-SC9P-288F-M

AR-SC9P-432F-M

AR-SC9P-576F-M



## 1. Optical Splice Trays

This Installation Manual suits for AR-SC9P-xxF-M Splitter Splice Closure (Hereafter abbreviated as SC), as the guidance of proper installation. AR-SC9P-xxF-M splitter closure can install various kind of PLC or box splitter; it is especially for FTTH project. The scope of application is: aerial, underground, wall-mounting, handhole-mounting and duct-mounting. The ambient temperature ranges from -40°C to +65°C.

## 2. Basic structure and configuration

### 2.1 Dimension and capacity

<b>Outside dimension (Height x Diameter)</b>	590mm×310mm
<b>Weight (excluding outside box)</b>	About 7.15 kg
<b>Number of inlet/out ports</b>	Mini cable 32 pcs, Fiber cable 9 pcs
<b>Diameter of fiber cable</b>	Mini cable $\Phi 5\sim\Phi 9$ mm, fiber cable $\Phi 8\sim\Phi 20$ mm
<b>Capacity of SC</b>	Bunchy: 12-960cores

### 2.2 Main components

No	Name of components	Quantity	Usage	Remarks
1	SC cover	1 piece	Protecting fiber cable splices in whole	Height x Diameter 489mm x 264mm
2	Fiber optic splice tray (FOST)	Max.80trays (bunchy)	Fixing heat shrinkable protective sleeve and holding fibers	Bunchy: 6,12 cores
3	Splitter tray		Fixing splitter	Configuration as per requirement
4	Fiber holding tray	1 pcs	Hold the fiber with sleeves	
5	Base	1set	Fixing internal and external structure	
6	Plastic hoop	1set	Fixing between SC cover and base	

No	Name of components	Quantity	Usage	Remarks
7	Sealing ring	1 set	Big gasket ring is used to seal SC cover and base. Small gasket ring is used to seal entry/exit tube	
8	Hose clamp	10 pcs	Use for fixing the fiber cable	Configuration as per requirement
9	Plastic gasket	8 set	Protect elastic seal rings from corruption	
10	Pressure testing valve	1 set	After inject air, it is used for pressure testing and sealing testing	Configuration as per requirement
11	Earthing deriving device	1 set	Deriving metallic parts of fiber cables in SC for earthing connection	Configuration as per requirement

## 2.2 Main components

No	Name of components	Quantity	Usage	Remarks
1	Heat shrinkable protective sleeve		Protecting fiber splices	Configuration as per capacity
2	Nylon tie		Fixing fiber with protective coat	Configuration as per capacity
3	Earthing wire	1 pc	Putting through between earthing devices	
4	Special wrench	2 pcs	Installing and tightening nut of reinforced core and nut (plastic) of entry/exit tube	
5	Desiccant	2 bags	Put into SC before sealing for desiccating air	
6	Metal wall mounting	1 set	For wall mounting	
7	Metal pole mounting	1 set	For pole mounting	

No	Name of components	Quantity	Usage	Remarks
8	Buffer tube	m	Hitched to fibers and fixed with FOST, managing buffer.	Configuration as per requirement
9	Sealing tape	1 ring	For the port of straight through	
10	Insulating tape	1 roll	Enlarging diameter of fiber cable for easy fixing	

### 3. Necessary tools for installation

#### 3.1 Supplementary materials (to be provided by operator)

Name of materials	Usage
Scotch tape	Labeling, temporarily fixing
Ethyl alcohol	Cleaning
Gauze	Cleaning

#### 3.2 Special tools (to be provided by operator)

Name of tools	Usage
Fiber cutter	Cutting off fiber cable
Fiber stripper	Strip off protective coat of fiber cable
Combo tools	Assembling SC

#### 3.3 Universal tools (to be provided by operator)

Name of tools	Usage and specification
Band tape	Measuring fiber cable
Pipe cutter	Cutting fiber cable
Electrical cutter	Take off protective coat of fiber cable
Combination pliers	Cutting off reinforced core
Screwdriver	Crossing/Paralleling screwdriver
Scissor	----
Waterproof cover	Waterproof, dustproof
Metal wrench	Tightening nut of reinforced core

### 3.4 Splicing and testing instruments (to be provided by operator)

Name of instruments	Usage and specification
Fusion Splicing Machine	Fiber splicing
OT DR	Splicing testing
Provisional splicing tools	Provisional testing

**Notice:** The above-mentioned tools and testing instruments should be provided by the operators themselves.

## 4. Installation flow chart

**1.** Open the closure

---

**2.** Installing and fixing the splitter

---

**3.** Determine length of fiber cable to be fixed and stripped inside SC

---

**4.** Strip off protective coats of fiber cable and fiber

---

**5.** Separate fiber cores and prepare work prior to fixing fiber cable

---

**6.** Encapsulate, fix fiber cable and reinforced core

---

**7.** Splice fiber and pigtail

---

**8.** Install heat shrinkable protective sleeve and house fibers

---

**9.** Fixing the splitter, pigtail and mini cable

---

**10.** Check up comprehensively

---

**11.** Assemble SC housing and fix SC

---

## 5. The process of installing SC.

### 5.1 Step one-Open the closure

Cleaning the locale and determine where to install the SC and then place fiber cables required. Check whether the main components and accessories have been well prepared inside the package.

Open the closure

- (1) Demount hoop fixing bolt and pull hoop locking system out, then proceed in demounting the hoop.
- (2) Pull the SC cover upwards out, installation could begin. See Drawing 1

**Important issues:** If the weather condition is not good enough, then a tent must be pitched for waterproof and dustproof.

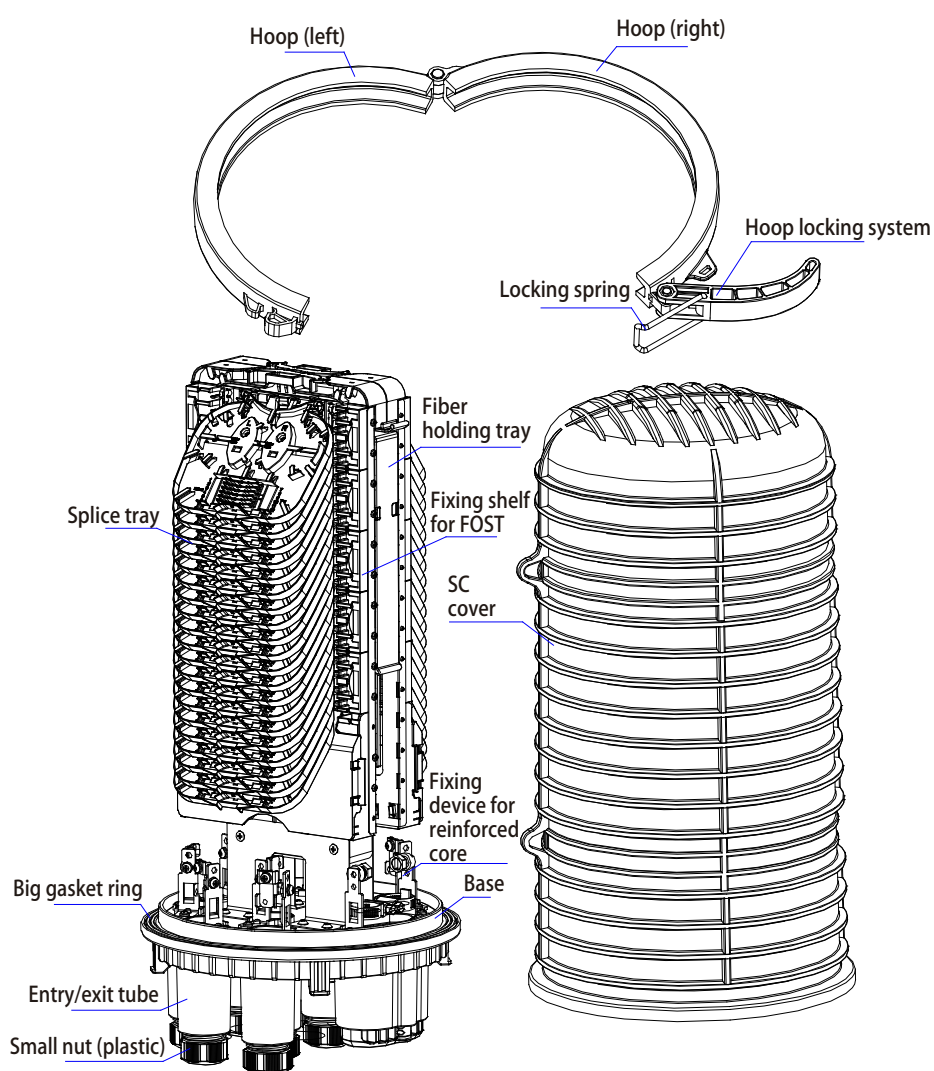

**DRAWING 1**

## 5.2 Step two-Installing and fixing the splitter

According to the customer's need to install, if you need to install a PLC optical splitter, the optical splitter can be installed in the card slot in the splitter tray, if you install more than 2 splitters, the splitter can be installed at different splitter tray. See drawing 2.

**Important issues:** PLC should reserve enough fiber, and swirling the redundant fiber in the splitter tray.

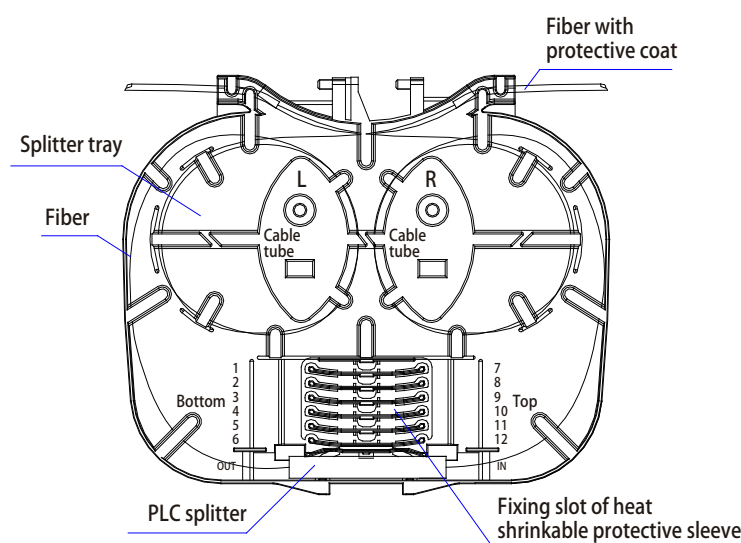

**DRAWING 2**

## 5.3 Step Three - Determine length of fiber cable to be fixed and stripped inside

**5.3.1** According to the requirement, the ports are installed with fiber cable or mini cable.

**5.3.2** The fibers which are in the SC are used for branching splice. The length of stripping cable show in 3-1.

**5.3.3** a part of fiber cable for straight through, a part for branching splice, The length of stripping cable show in 3-2.

### **Important issues:**

- (1) Reserve enough fiber cable.
- (2) Determine the length of stripping cable.
- (3) The customer can decide the stripping cable length by themselves if they have other requirement.

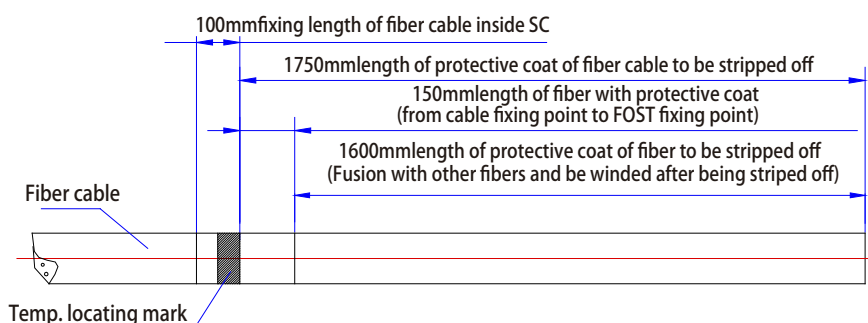

**DRAWING 3-1**

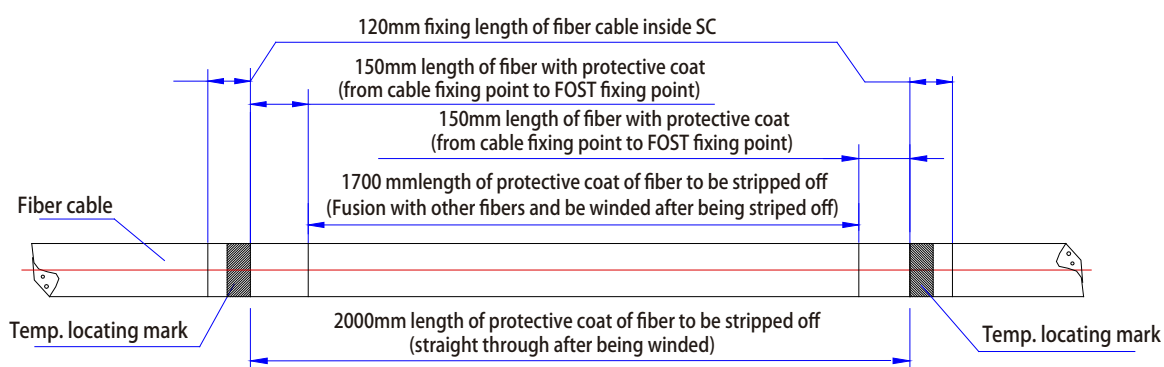

**DRAWING 3-2**

## 5.4 Step four - Strip off protective coat of fiber cable and fiber

Strip off protective coat of fiber cable from the temp. Locating mark with the cutter and the stripper, please refer to Drawing 3 for stripping length. Stripping length also could be decided according to installation requirement. See Drawing 4.

**Important issues:** If it is difficult to pull all the protective coat of fiber cable at one time, strip it off section by section to avoid fiber breakage.



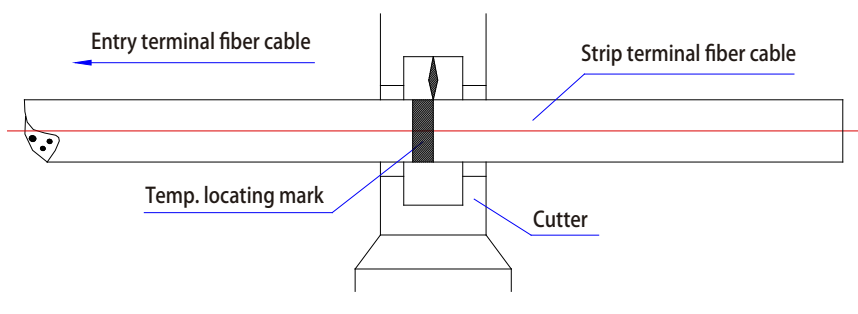

**DRAWING 4**

## 5.5 Step Five - Separate fiber cores and prepares work prior to fixing fiber cable

**5.5.1** Wind 2 layers of insulation tape on protective coat of fiber core for protection. Meanwhile, get rid of the stuffing to separate fiber core and clean them. Form a ring with the diameter of 100mm or so and fix it on the fiber cable temporarily by adhesive tape.

**5.5.2** According to stripe cable, it has two kinds: (1) fibers are branched after splice ;(2)one part fibers are straight-through after coil, the others are spliced with branch fiber.

**5.5.3** This closure has 9 inlet/outlet ports at the end case.8 pcs of small ports can install with 1pc of max. diameter 20mm cable or 4pcs of 5-9mm mini cable. 1pc of oval big ports can install with 1pc of max.diameter20mm for straight through, or 2pcs of max diameter 20mm cables for branching.

**5.5.4** One part of fiber need to straight through, it should choose oval port to install.

- Important issues:**
1. Inlet/outlet tubes are to be selected accurately to make it easy for splicing and sealing.
  2. Reserve reinforce core for 40mm, then cut off the unnecessary

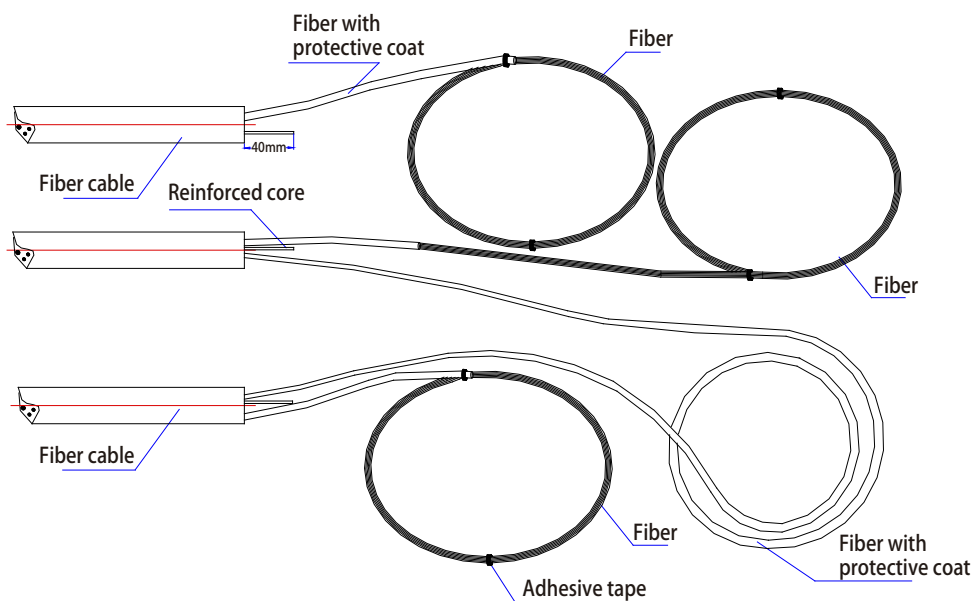

**DRAWING 5**

## 5.6 Step Six - Encapsulate, fix fiber cable and reinforced core

**5.6.1** Install the normal cable in the small port: according to the diameter of the cable, choose the suitable sealing ring. Demount the nut, gasket and sealing ring of the corresponding entry/exit tubes, insert them into fiber cable in sequence, and then insert fiber cables into entry/exit cable. Fix cable and reinforced core: according to the diameter of the cable, use the suitable hose clamp jammed in the slot of reinforced core device. Then put the hose clamp on the cable, let the cable 5mm above the hose clamp, tighten the nut in order to fix the cable. After that, release the reinforced core device, through the core and screws. Finally put the small sealing gasket, gasket ring, nut through the tube, tighten the nut in order to seal properly.

**5.6.2** Install the mini cable in the small port: First according to the mini cable way and put it into the sealing ring, fixed the mini cable reinforced core, and then together through cable access port, fixed mini cable components, then tighten the nut in order to seal properly.

**5.6.3** The big port for straight splice and part branch: should be based on the actual installation of the cable diameter, use the appropriate double-hole sealing. Unscrew the two fastening screws, platen, double hole ring and washer, and then put the tube into the ports, At last put the gasket, double hole ring, and the plastic platen, and finally tighten two fastening screws to ensure sealing.

**5.6.4** Uncutting cable and the fix the reinforced core: according to the diameter of the cable, choose the right hose clamp, jammed in the slot of reinforced core base. Then put the hose clamp on the cable, let the cable 5mm above the hose clamp, tighten the nut in order to fix the cable. After that, release the reinforced core plate, through the core and screws; fix the direct through cable in the storage tray 5.6.5. Demount the nut of fixing device of reinforced core with special wrench (plastic one), set the reinforced core into fixing slot, tighten the nut, and retighten it with metal wrench (metal wrench to be provided by operator). See drawing 6

**Important issues: tighten the reinforce core fixing screws.**

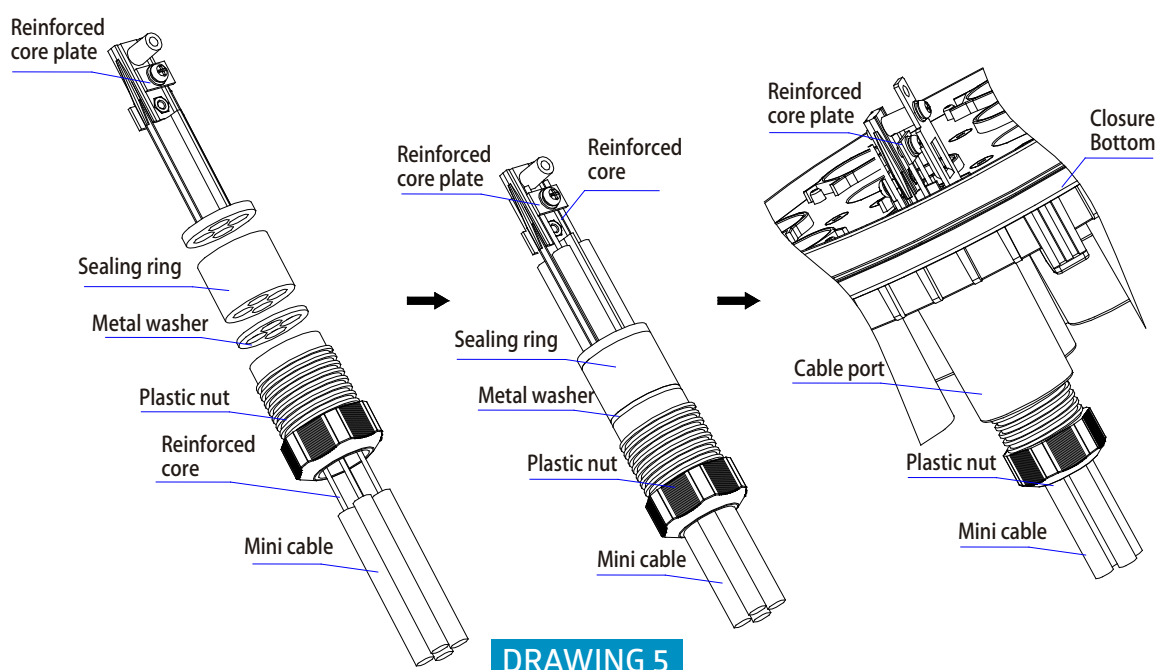

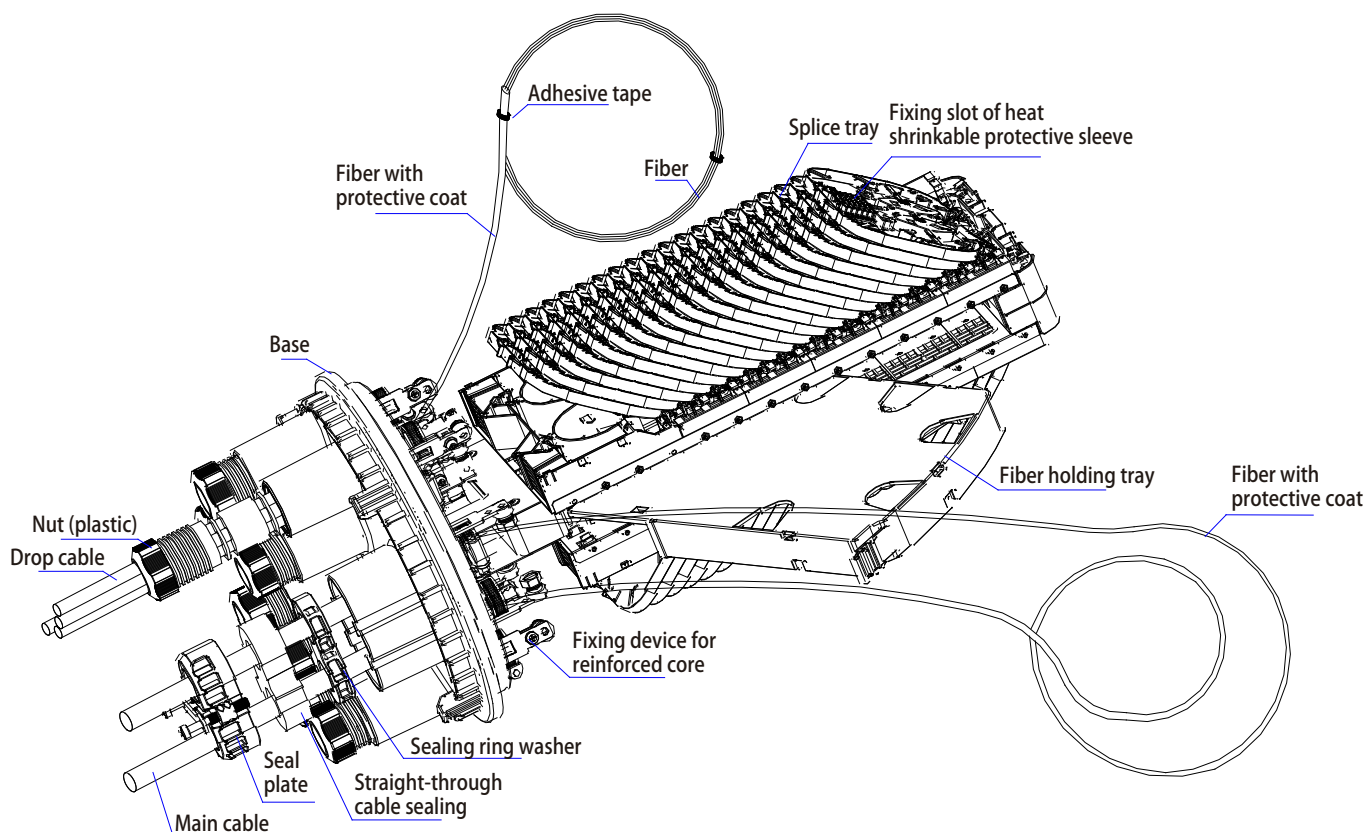

**DRAWING 6**

## 5.7 Step seven - Fiber splicing

Follow user manual of fusion splicing machine to splice fiber.

**Important issues:** pay attention to the twist and bend of fiber.

## 5.8 Step eight - Install heat shrinkable protective sleeve and house fibers

When having completed splicing the fibers, the first fiber ring should be housed on the farthest side of FOST, the remaining fiber should be wound, forming a ring with diameter not less than 60mm. then put it into FOST (Fiber Optic Splice Tray) together with heat shrinkable protective sleeve.( Firstly fix heat shrinkable protective sleeve into the slot, then enlarge the diameter of fiber ring properly.) See drawing 7

**Important issue:** pay attention to the twist and bend of fiber.

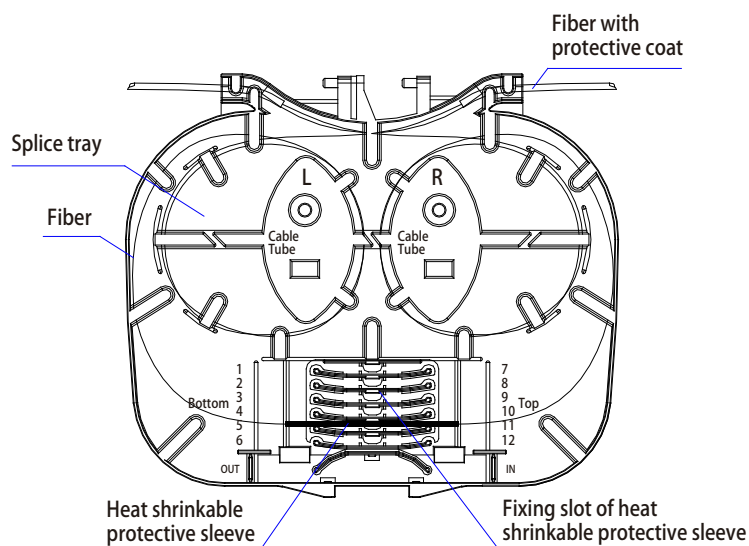

**DRAWING 7**

## 5.9 Step nine – Check up comprehensively.

**5.9.1** The drop cable according to the appropriate route by the coil and fixed.

**5.9.2** Drop cable routing see drawing 8.

**5.9.3** For splitting and optical wiring, install the splitter as shown in the drawing 2, coil and fixed the input and output pigtailed.

**5.9.4** If need splitting, wiring and install the adapter, please follow the drawing 9 icon to install the adapter panel, and the input and output of the pigtail coiled and fixed.

**5.9.5** Check whether the internal tightness and reinforced core are well tightened.

**5.9.6** Check whether gasket ring is installed neatly and smoothly without any breakage. If not, level it up with seal tape. See drawing 10

**Important issues:** If any problems occur, they should be solved right away.

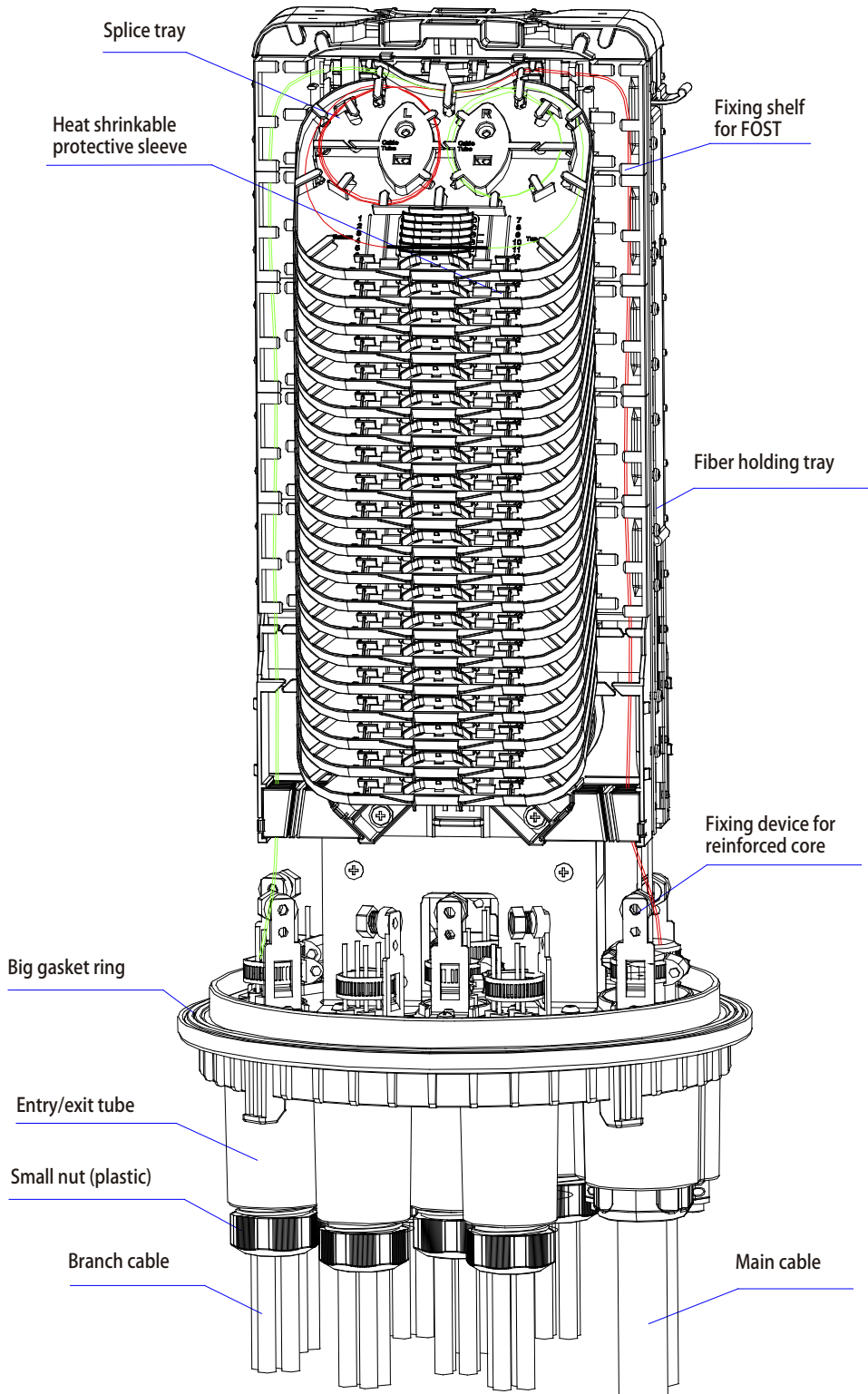

**DRAWING 8**

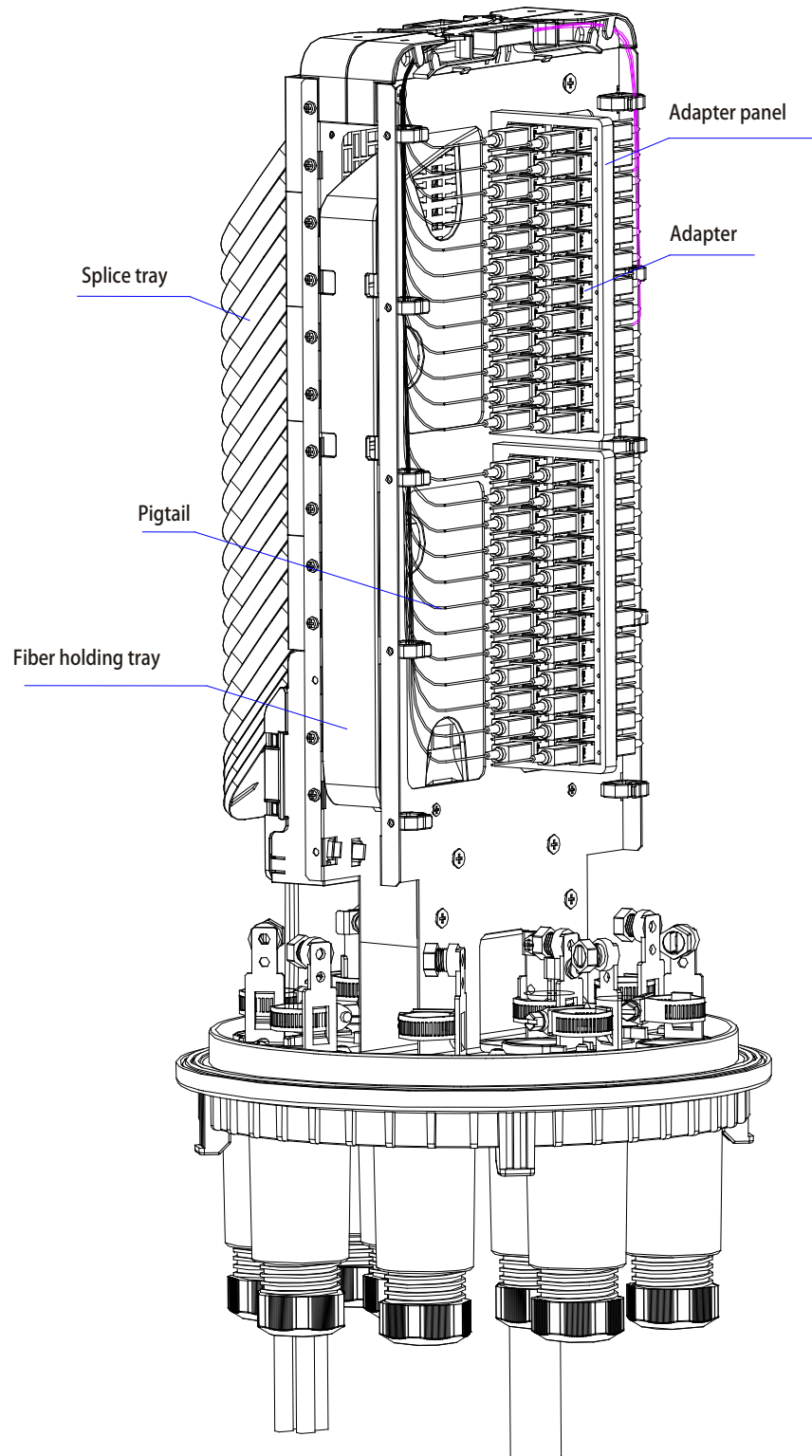

**DRAWING 9**



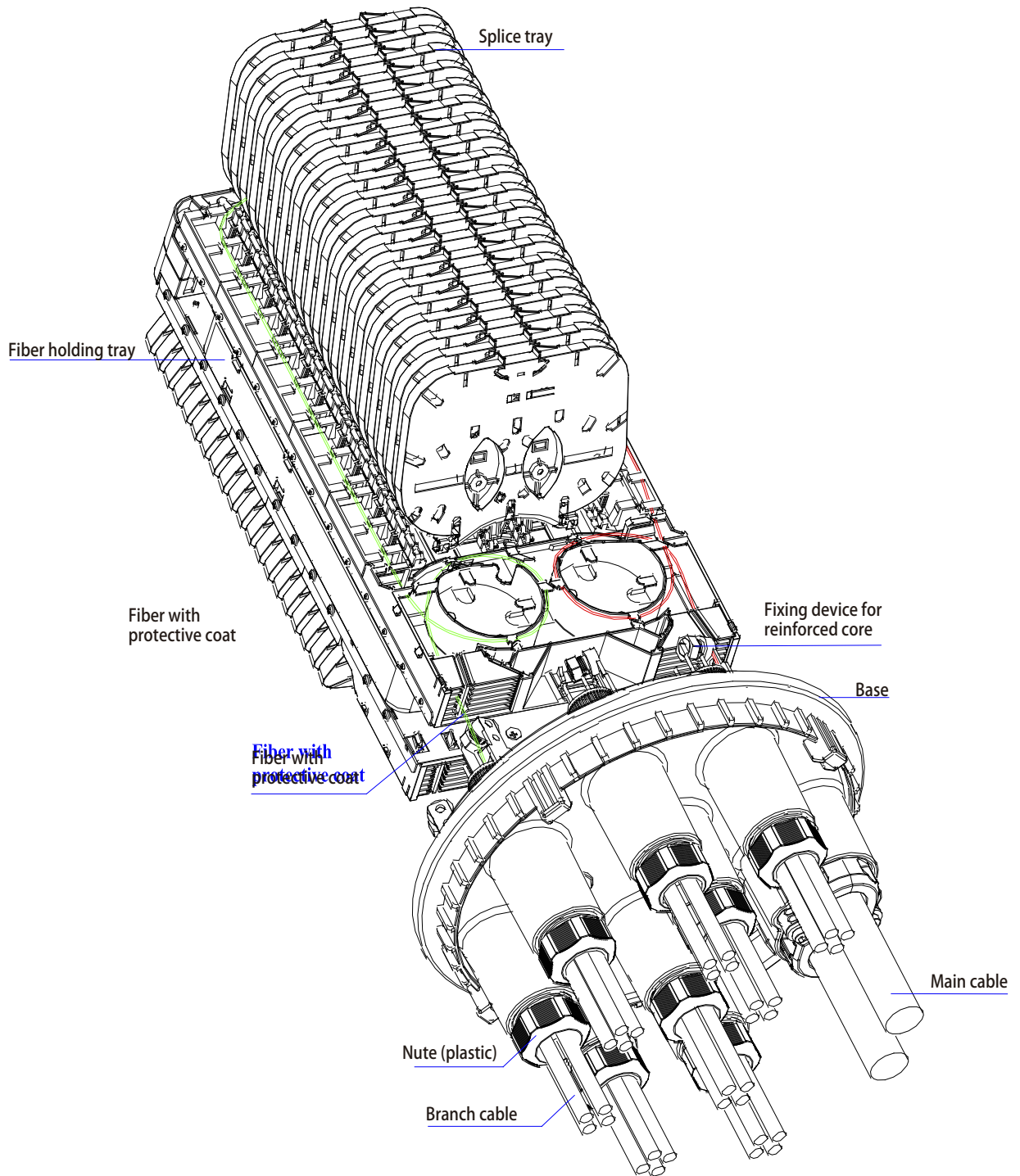

**DRAWING 10**

## 5.10 Step ten – Assemble SC housing and fix SC

**5.10.1** Put the desiccant into the closure

**5.10.2** Put SC cover on base directly.

**5.10.3** Install plastic hoop between SC cover and the base, tighten hoop locking system, which is to be fixed by hoop fixing bolt then.

**5.10.4** All nuts (plastic ones) of base need to be retightened once more.

**5.10.5** SC installation

- (1) Wall-mounting: Before installing the optical cable, first assemble the wall hanging on the bottom of the box. At last, use expansion screws to fix it on the wall. See drawing11.
- (2) Pole-mounting installation: Fixed metal hoop and transom to the pole. See drawing12

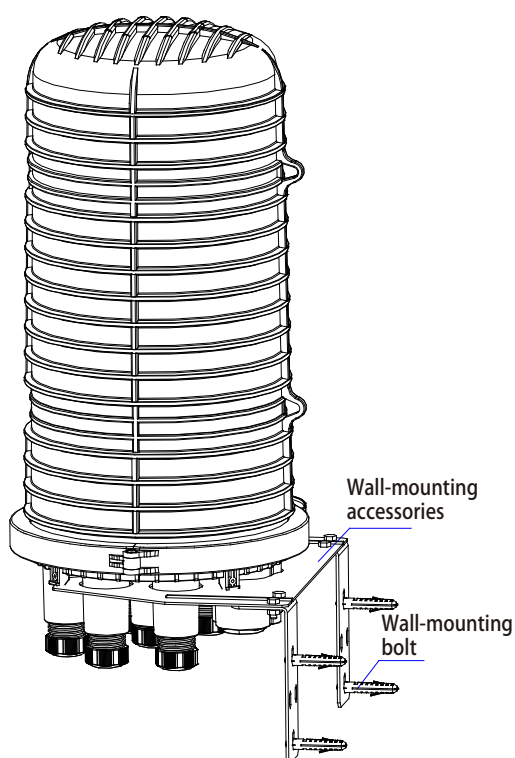

**DRAWING 11**

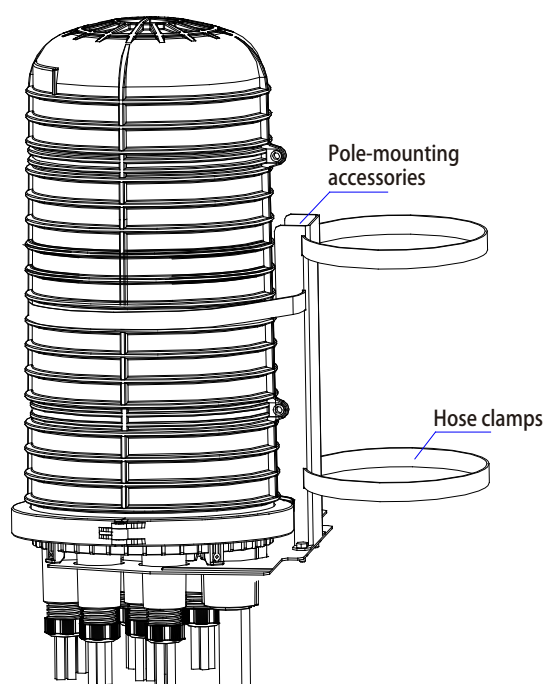

**DRAWING 12**